

ITEM NO.	PART NUMBER	PartNo	DESCRIPTION	QTY.
1	15520-000-1	103534	FOIL FEED, 6X8 6X12, NO DRIVE	1
2	15800-000	101168	Foil Feed Electric Motor Mount	1
3	15000-003	102953	Knurled roller pin (drive side)	1

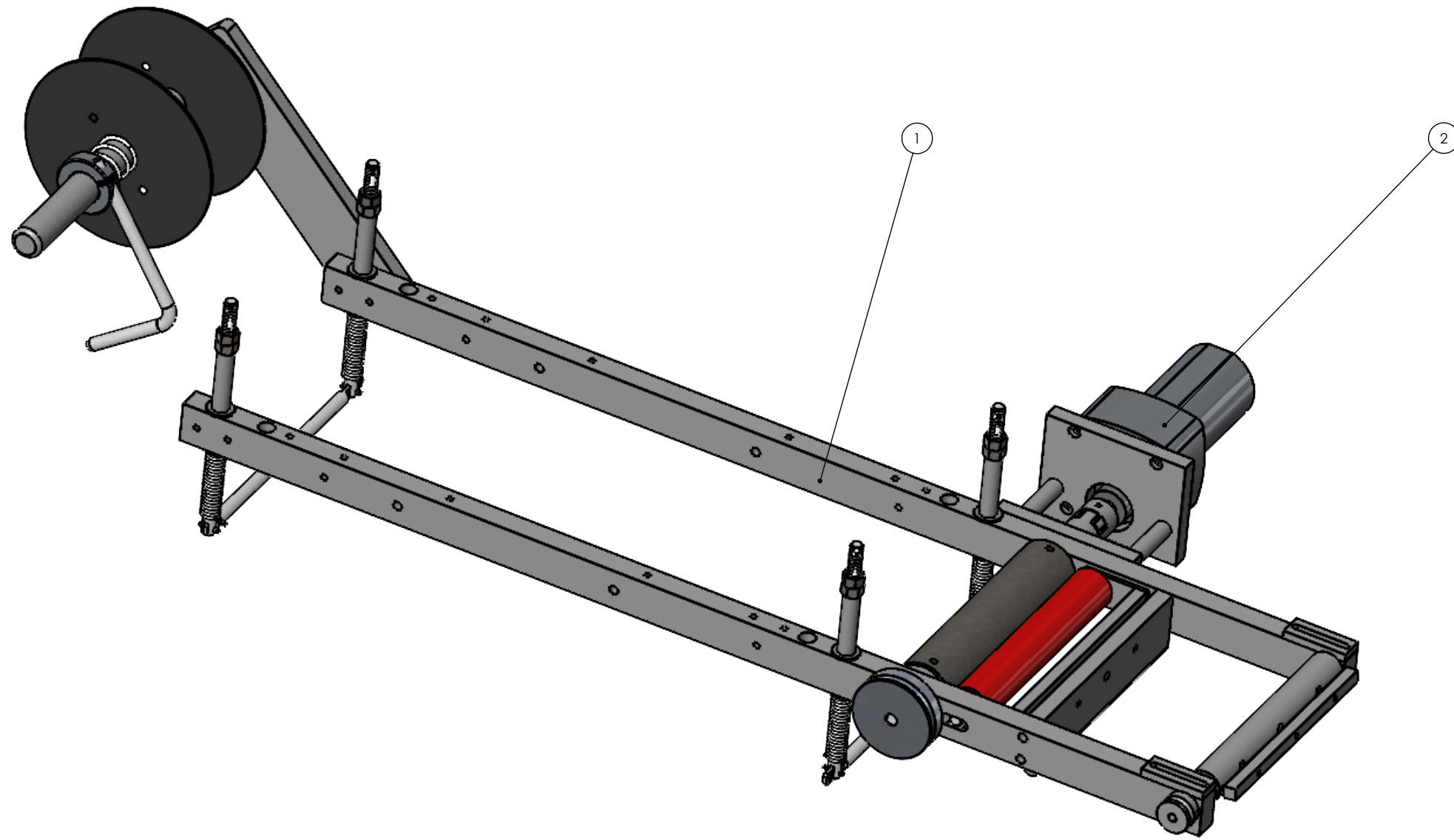

PROPRIETARY AND CONFIDENTIAL
 THE INFORMATION CONTAINED IN THIS DRAWING IS THE SOLE PROPERTY OF AFM ENGINEERING, INC. ANY REPRODUCTION IN PART OR AS A WHOLE WITHOUT THE WRITTEN PERMISSION OF AFM ENGINEERING INC. IS PROHIBITED.

DIMENSIONS ARE IN INCHES		NAME	DATE	AFM Engineering, Inc.
TOLERANCES:		DRAWN	Irwin	
FRACTIONAL ±		CHECKED	Irwin	-
ANGULAR: MACH ± BEND ±		ENG APPR.		
TWO PLACE DECIMAL ± .010		MFG APPR.		
THREE PLACE DECIMAL ± .005		Q.A.		
MATERIAL		COMMENTS:		AFM Engineering, Inc. FOIL FEED, 6X8 6X12, DC MOTOR DRIVE AFM PART # 104339
NEXT ASSY	USED ON			
FINISH				SIZE DWG. NO.
APPLICATION		DO NOT SCALE DRAWING		B 15520-000-1_Electrical
				SCALE: 1:8 WEIGHT: 17.096 SHEET 1 OF 1