

George R. Peters Associates ENGINEERING SALES REPRESENTATIVES

650 E. Big Beaver • Suite C • Troy, MI 48083
(248) 524-2211 • Fax (248) 524-1758
www.grpeters.com

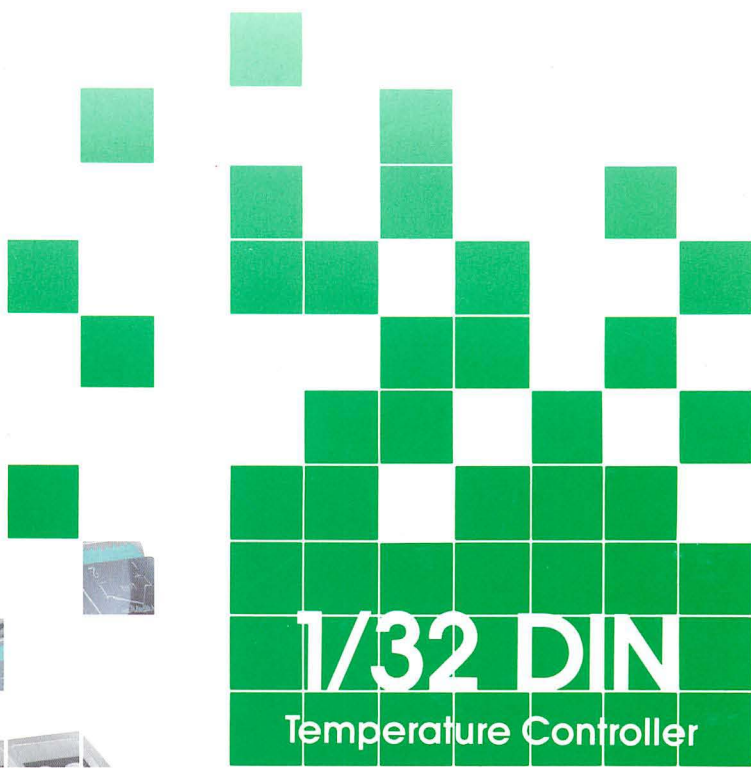

1/32 DIN
Temperature Controller

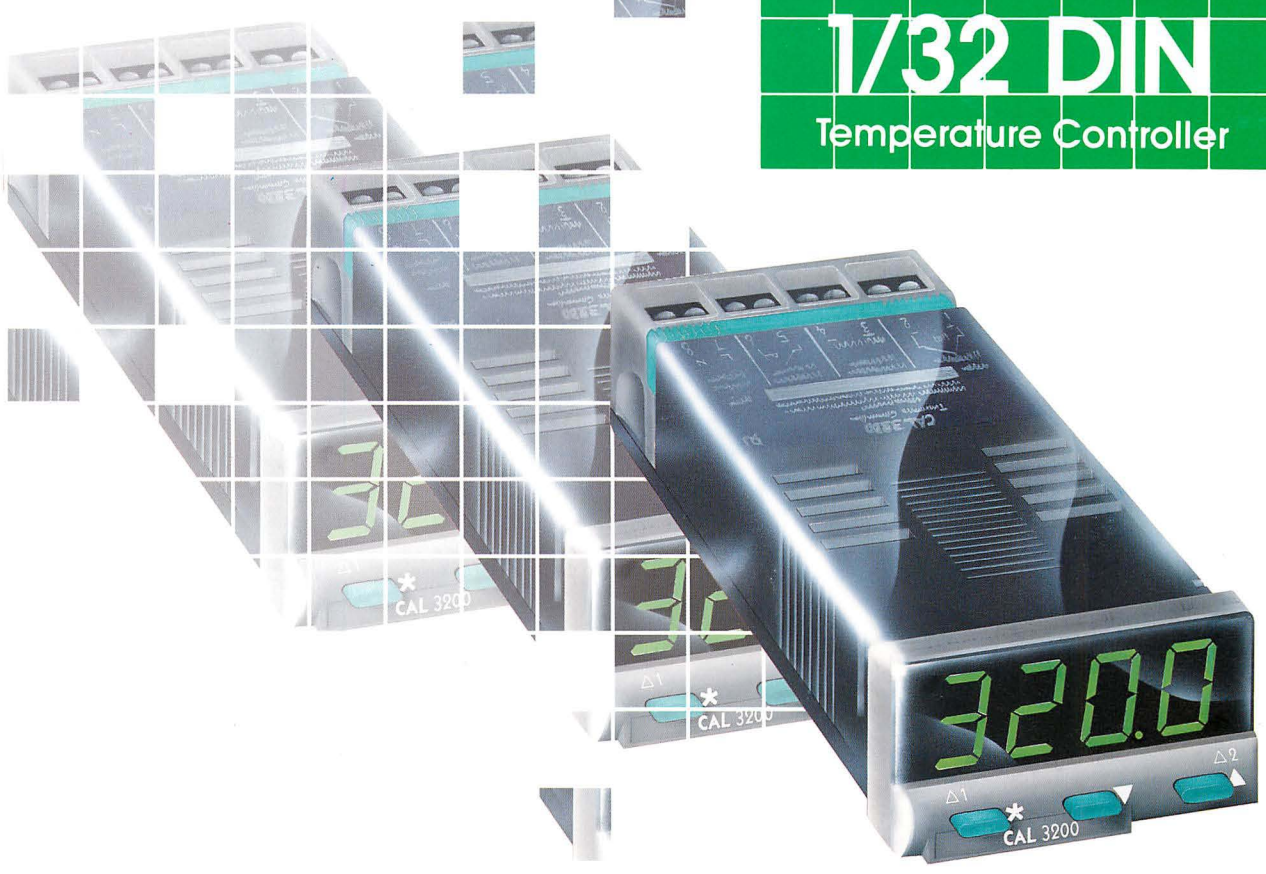

CAL 3200

George R. Peters Associates ENGINEERING SALES REPRESENTATIVES

650 E. Big Beaver • Suite C • Troy, MI 48083
(248) 524-2211 • Fax (248) 524-1758
www.grpeters.com

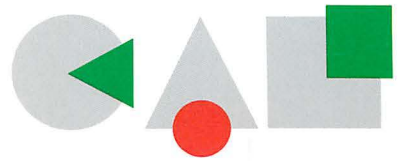

CAL Controls
Temperature Controllers

C A L

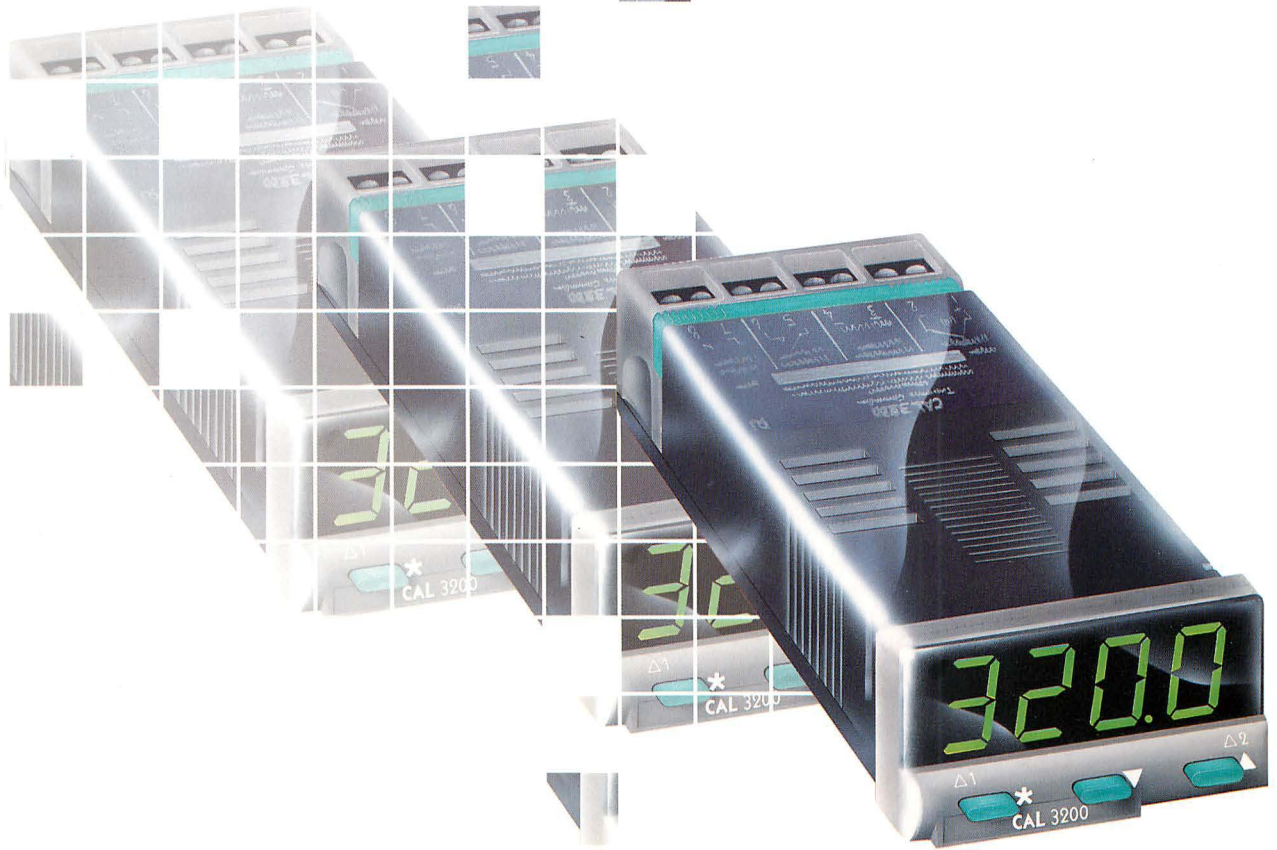

One step ahead ... again

By combining advances in technology with an original concept we produced a 'first' in 1986 – the 1/16 DIN CAL 9000 PID digital controller – leading to 1/16 DIN becoming the new industry standard format for digital temperature control

Now, our development work enables us to create another imaginative first: the CAL 1/32 DIN. It offers a new dimension in full-feature autotune PID digital temperature control with all the accuracy, reliability, versatility and value today's industry demands

There's no compromise on clarity or ease of use, so it features a large display and keys, helpful set-up mnemonics and water-resistant NEMA 4X/IP65 panel, plus safety approvals and CAL's proven rugged construction

30
years
temperature
control
innovation

3 2 0 0

Main Features

3 year warranty

Ultra compact size: 1/32 DIN

... with no compromise on function



Shown actual size

Autotune of PID values, approach control and calculation of ideal cycle-time

... automatically matches control characteristics to the application

Dual output: 2A relay + SSR drive

... control channel plus alarm or heat-cool

NEMA 4X/IP65 sealed fascia

... withstands hostile environments and washing down

4 bright LED digits display to 1°/0.1° in °C/°F

... clearly readable from a distance even in bright light

Tactile keys with positive 'feel'

... ergonomic layout for ease of use

5 alarm modes with latch and sequence option

... matches alarm needs without spurious power-up alarms

All popular sensors selectable

... 9 thermocouples, RTD/Pt100 and linear process inputs

User friendly mnemonic menu with operator lockouts

... for easy setting-up and operational security

Matching panel adaptors for 1/16 DIN cutouts

... for a neat fit of 1 or 2 × 3200 controllers

A NEW DIMENSION

Adaptors for fitting 3200(s) in 1/16 DIN panel cutouts



1/16 DIN 3200 adaptor
Accepts one 3200



1/16 DIN 3200 twin adaptor
Accepts two 3200's

PANEL SPACE REQUIRED:

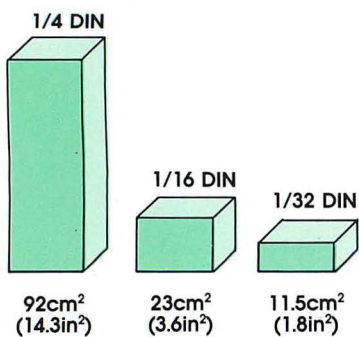

Today, small is not only beautiful – it's powerful too!

Advanced technology comes in smaller and smaller packages. Today's hand-held computers or automatic cameras have the processing power of a room-full of 1970s computers, and these gains in speed and capability owe much to the miniaturisation of circuits – now often smaller than a postage stamp

There are two good reasons for industrial control products to take advantage of the technology which makes this power-to-size increase possible: greater benefits and better value for money

With this in mind, we applied the concept to industrial temperature controllers: the result is the 1/32 DIN CAL 3200, backed by thorough development and our 30 years experience in the field. Efficient, automated production and computer-assisted test equipment ensure consistent quality and reliability

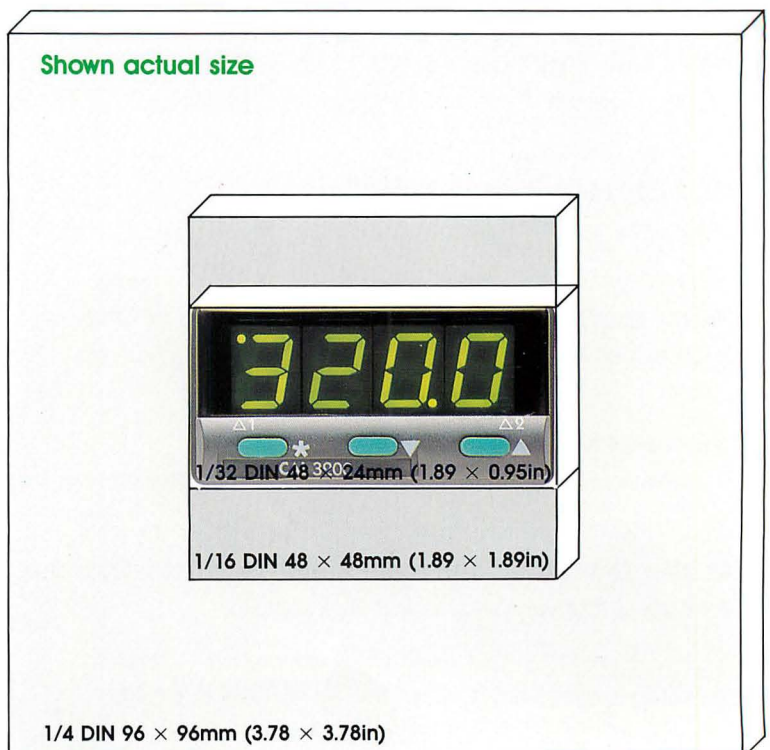

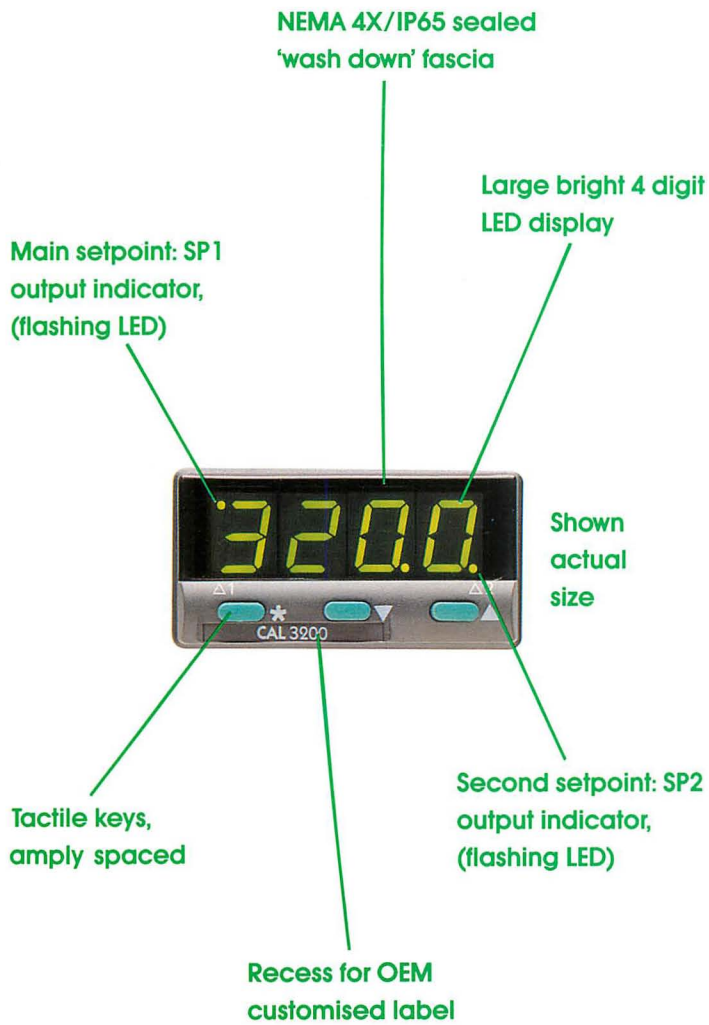
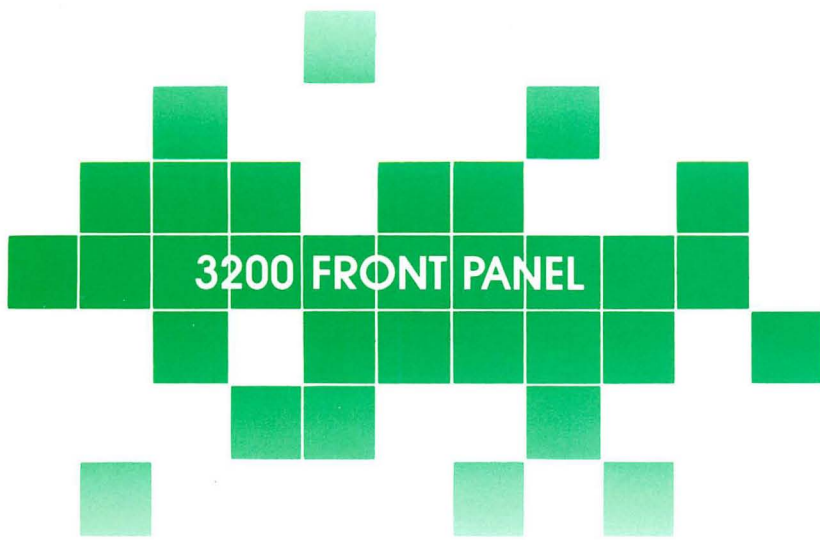

Displaying

Normal display:
Process temperature



Setpoint with unit (°C, °F etc)

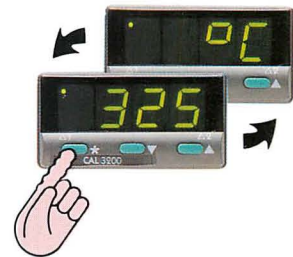

Adjustment of setpoint



Entry to program mode



Alternating display:
Autotuning (shown), alarm etc



3200 VERSATILITY

Input sensors

For full data see page 10

All popular sensors are included, these are accurately linearised over their full usable range

Thermocouples – 9 types

type	range	maximum
B	1800°C	3272°F
E	600°C	1112°F
J	800°C	1472°F
K*	1200°C	2192°F
L	800°C	1472°F
N*	1200°C	2192°F
R	1600°C	2912°F
S	1600°C	2912°F
T*	250°C	482°F
RTD*		
Pt100	400°C	752°F

Range minimum: 0°C/32°F, except (*): see page 10

Linear process inputs and ranges: see page 10

Ranging

For plant safety or production efficiency the setpoint adjustment may be limited to a maximum, and/or minimum, temperature over any portion of the sensor range

Example: Setpoint limited to 400° – 600°C

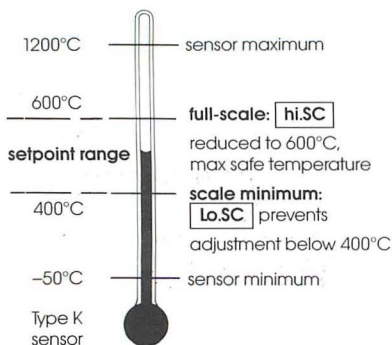

Autotune

The advanced 'one shot' autotune algorithm helps automate system start-up and maintain good control over a wide range of process conditions

In addition to the normal PID terms (proportional band, integral time, derivative time) the algorithm also tunes:

- Derivative approach control (DAC) which minimises overshoot by tuning warm up characteristics independent of normal operation
- Ideal cycle-time is calculated ready for manual acceptance if compatible with the external device: contactor, SSR, valve etc

To ensure good control over a wide range of applications, the 3200 includes two versions of the algorithm

Tune

This method normally achieves the best results. Starting with the load cool, tuning occurs during warm-up preventing overshoot

Tune at setpoint

Useful for specialist applications eg. heat-cool, multizones and processes below 100°C/200°F. During the tuning cycle some overshoot occurs because the tuning cycle is at setpoint. DAC is not re-calculated

The autotune – TUNE program

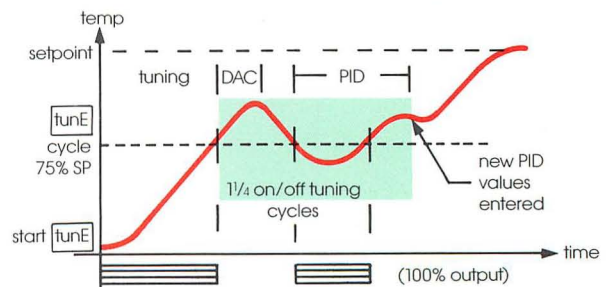

The autotune – TUNE AT SETPOINT program

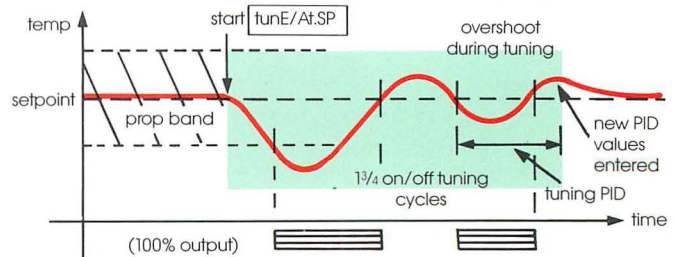

3200 FUNCTIONS MENU



Mnemonic aided menu
Function/Option alternate:
eg. Proportional band
(autotuned) 5.8°C/F

MENU LEVEL

LEVEL	Derivative sensitivity	Display sensitivity	Disable alarm annunciator	Disable program auto-exit	Security lock
4	dEr.5	d.5.5	no.AL	ProG	LoCk

SECURE LEVEL

3	Read SP1 output device	Read SP2 output device	Burn-out protection	Select output modes: Direct/Reverse	Select SP1/2 LED modes	Sensor span adjust	Zero sensor error	Control accuracy monitor	Read Autotune tuning data	Software version	Functions Reset
	SP1d	SP2d	burn	REUD	REUL	SPAn	Zero	CHED	data	VER	RESET
	OUTPUT CONFIGURATION			TECHNICAL							

2	Read SP1 output power %	SP1 manual power control %	Set SP1 power limit %	Set SP2 power limit %	Main SP2 operating mode: Alarms/Cool strategy	Subsidiary SP2 mode: Alarm (latch/sequence)	Select display resolution 1°/0.1°	Set full scale	Set scale minimum	Select input sensor	Select °C/°F or units
	SP1A	hAnd	PL1	PL2	SP2A	SP2B	d.SP	h.5C	Lo.5C	inPt	unit
	MANUAL CONTROL MODES			SP2 OPERATING MODES		INPUT SELECT & RANGING					

1	Select Autotune or Park	Proportional band/Gain or Hysteresis	Integral time/Reset	Derivative time/Rate	Derivative approach control	Proportional cycle-time or ON/OFF	Offset/Manual reset	Lock main setpoint SP1	Adjust SP2 setpoint	Select SP2 Hysteresis or Proportional band	SP2 ON/OFF or cycle-time
	tune	bAnd	intt	dEr.t	dAR	CYCL	oFSt	SP1L	SEt.2	bAnd.2	CYCL.2
	SP1 OPERATING PARAMETERS						SP2 OPERATING PARAMETERS				

Alarms



SP2 may be configured to act on any one of the 5 alarm conditions shown below:

Deviation alarms

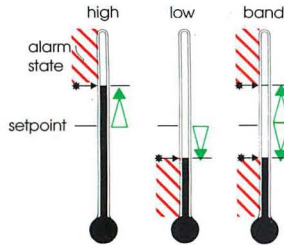

Full scale alarms

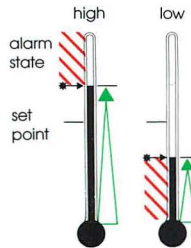

Sequence alarm

When selected, in any alarm mode, prevents an alarm on power up. The alarm is enabled only when the process temperature reaches setpoint

Example: Sequence alarm used with deviation low alarm

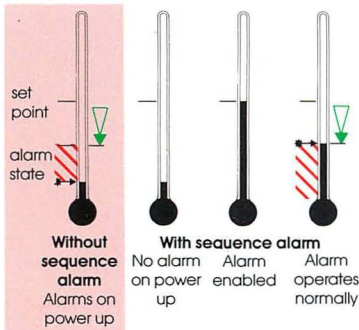

Latch

If selected the alarm output and indicator latch, reset by pressing ▼ ▲ together

ULTIMATE SAFETY ALARMS

Normal safety advice: Do not use SP2 as the sole alarm where personal injury or damage may be caused by equipment failure

Cool strategy for heat-cool applications

The 3200 cool strategy provides a comprehensive solution to demanding heat-cool applications, either air or water cooled

- Linked heat and cool channels move together under PID control eliminating offset and providing a consistent deadband
- Cool proportional band, relative cool, deadband and cool power limit adjustments. Non-linear cool channel for flash-to-steam systems
- Autotune speeds setting up by tuning the heat channel and providing recommended cool channel settings

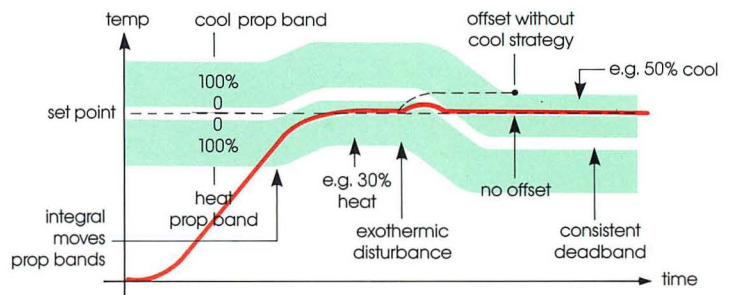

Tools to improve control accuracy

Control accuracy monitor

This enables the accuracy of the temperature control to be established within 0.1°C/°F. The variance (deviation) maximum and minimum temperatures are displayed and constantly updated

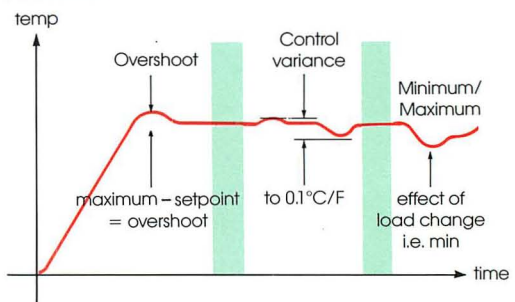

Output percentage power monitor

The duty cycle monitor indicates if the heater to load ratio is compatible with good control

Error messages and diagnosis



Clear mnemonic messages show fault conditions e.g. input sensor failure

Autotune tuning cycle data is available for display

Multi-level operator lockouts are provided by the 'lock' function, secure for OEM use only in hidden level 4. The 'lock' prevents unauthorised adjustments of program functions but allows the current options to be read

Multi-level lock: minimum maximum
levels secured:

Setpoint lock: Prevents unauthorised setpoint adjustment

3200 BEHIND THE PANEL

3200 Rear

The sliding lock positively secures the connector

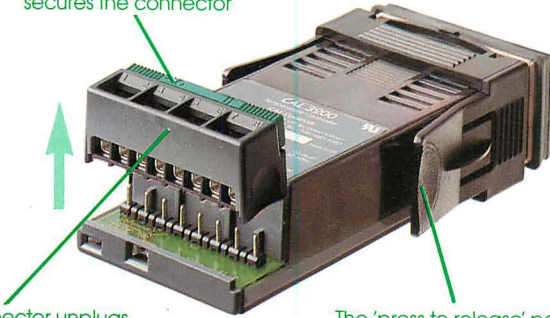

8 way connector unplugs, to pre-wire, or for rapid unit replacement

The 'press to release' panel clamp allows easy removal, useful in tight spaces

Dimensions mm(inch)

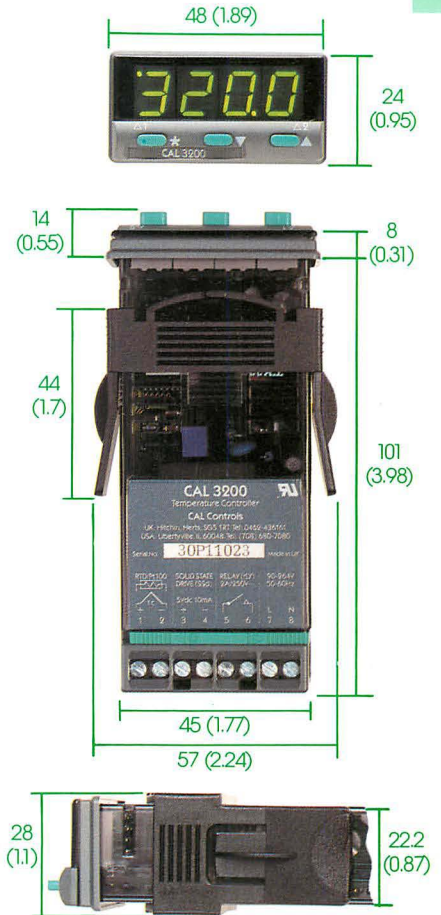

Panel cutout: 1/32 DIN

$45.0 + 0.6 / - 0 \times 22.2 + 0.3 / - 0$
 $(1.77 + 0.02 / - 0 \times 0.87 + 0.01 / - 0)$
 Max. panel thickness 10 (0.39)

Multiple 3200 installations

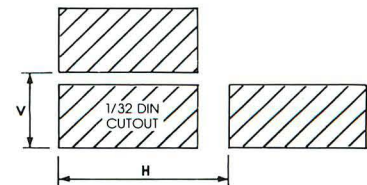

Guide for spacing:

	V	H
Minimum	30 (1.18)	60 (2.36)
Allows clamp removal	30 (1.18)	70 (2.76)
Allows clamp and connector removal	35 (1.38)	70 (2.76)

Recommended

Electrical connections and outputs

Dual outputs are standard, just key in the preferred output device for the main setpoint (SP1) to suit the application. Choose either the solid state relay drive (SSd) to switch a remote SSR, or the 2Amp/250V~ relay. The remaining output is automatically allocated to the second setpoint (SP2).

Example A

The SSd output is allocated to SP1 and wired to switch the load (heater) using an SSR

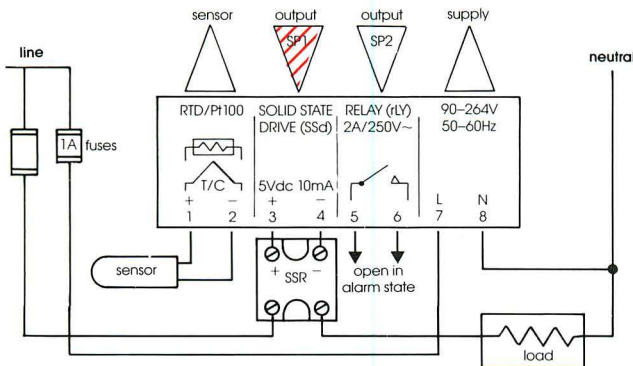

Example B

The relay output is allocated to SP1 and wired to switch the load (heater) using a contactor

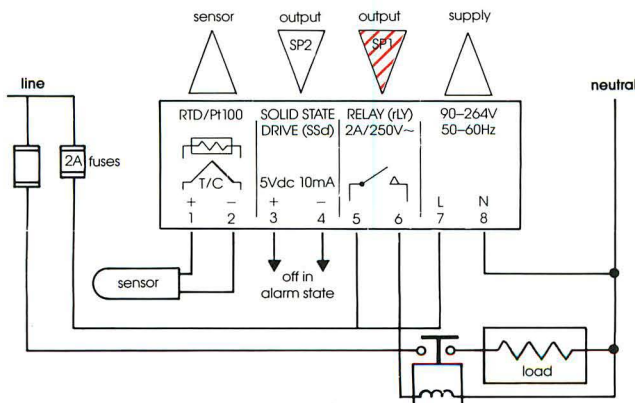

3200 SPECIFICATION

General

Line voltage:

90–264V 50–60 Hz

Switchmode power supply

Digital display:

4 LED 10mm (0.4in) digits,
green high brightness

Displaying:

Process temperature (PV) or
setpoint (SP) in: °C or °F

(Bar, PSI, Ph, rh displayed,
processed as °C)

Function/option mnemonics

Error messages

SP1/2 indicators (flashing)

Keypad:

3 tactile elastomeric keys

Range:

Sensor dependent: see 'Inputs'

Display range:

Normal: –250° to 3500°

Hi-res: –199.9° to 999.9°

Microcomputer:

Intel 83C51

8 bit, 16k PROM, 0.25k RAM,

12 MHz. Data retention:

10 years unpowered

Environmental

– Approvals pending

Conformity testing Jan 93

Safety:

UL873, VDE0411–1
CSA22.2/142–M1987

Protection:

Fascia NEMA 4X/IP65

EMC Emission:

EN50 081–1, VDE0871/78–B1

FCC Rules 15 s/part J, Class A

EMC Immunity:

EN50 082–2/B

Ambient: 0–50°C (32–130°F)

Weight: 100g (3.5oz)

Mouldings: FR polycarbonate

Pack: Recycleable styrene/6

Control Characteristics

SP1 Autotuned PID parameters

bAnd	Proportional band/Gain or Hysteresis	SM = sensor maximum 0.1–(25%SM) °C/°F e.g. Type K: 0.1–300°C/548°F
i n t t	Integral time/Reset	0.1–60 minutes or Off
d e r t	Derivative time/Rate	1–200 seconds or Off
d a c	Deriv. approach control	0.5–5 × Proportional band
c y c t	Proportional cycle-time	0.1–81 seconds or On/Off

SP2 Operating modes and parameters

s p 2 a	Deviation alarms	High, low, band (out of limits) ±0–(25%SM) °C/°F from setpoint
	Full scale alarms	High, low, 0–100% sensor range
s p 2 b	Alarm output action	Latching or non-latching
	Sequence alarm action	Alarm off till PV reaches setpoint

Cool channel when cool strategy selected

b n d 2	Cool Prop band/Gain	0.1–(25%SM) °C/°F or hysteresis
c y c 2	Cool Prop cycle-time	0.1–81 sec linear or non-linear
s e t 2	Heat-Cool deadband	±0–250°C/°F from setpoint
p l 2	Cool max power limit	0–100% duty cycle

Manual controls

s p 1 p	Read SP1 output power	0–100% duty cycle
h a n d	Manual heat power	0–100% e.g. if sensor fails
p l 1	Heat max power limit	0–100% duty cycle
p a r e	Park mode	Temporarily turns output(s) off. A commissioning aid

Safety, calibration and data

h i s c	Full scale	0–100% sensor range Including negative
l o s c	Scale minimum	
s p a n	Sensor span (and zero)	±0–(25%SM) °C/°F
b u r n	Burn-out protection	Upscale or downscale
r e u d	SP1/2 output and	Fully configurable (invert) e.g. direct/reverse
r e u l	indicator modes	
c h e c	Control accuracy check	Variance, max, min to 0.1°C/°F
d a t a	Autotune tuning data	10 tuning cycle results

3200 SPECIFICATION

Inputs



Thermocouples – 9 types

Type	Sensor range			Linearity ($\pm^\circ\text{C}$)
B	0 to 1800°C	32 to 3272°F	Pt-30%Rh/Pt-6%Rh	2.0*
E	0 to 600°C	32 to 1112°F	Chromel/Con	0.5
J	0 to 800°C	32 to 1472°F	Iron/Constantan	0.5
K	-50 to 1200°C	-58 to 2192°F	Chromel/Alumel	0.25*
L	0 to 800°C	32 to 1472°F	Fe/Konst	0.5
N	-50 to 1200°C	-58 to 2192°F	NiCroSil/NiSil	0.25*
R	0 to 1600°C	32 to 2912°F	Pt-13%Rh/Pt	2.0*
S	0 to 1600°C	32 to 2912°F	Pt-10%Rh/Pt	2.0*
T	-200 to 250°C	-273 to 482°F	Copper/Con	0.25*

(*): Linearity } B:5°(70°–500°C) K/N:1°>350°C
 exceptions } R/S:5°<300°C T: 1°<-25°>150°C

Standards: IPTS 68/DIN 43710

CJC rejection: 20:1 (0.05°/°C) typical

External resistance: 100Ω maximum



Resistance thermometer

RTD-2 wire	Sensor range		Linearity
Pt100	-200 to 400°C	-273 to 752°F	$\pm 0.25^\circ\text{C}$ $< -100^\circ\text{C} \pm 0.5^\circ\text{C}$

Standards: DIN 43760 (100Ω 0°C/138.5Ω 100°C Pt)

Bulb current: 0.2mA maximum



Linear process inputs

No. displays	0–20mV displays	4–20mV displays	Display range
1	0–100		0–400
2		0–100	-25–400
3	0–1000		0–3000
4		0–1000	-250–3000
5	0–2000		0–3000

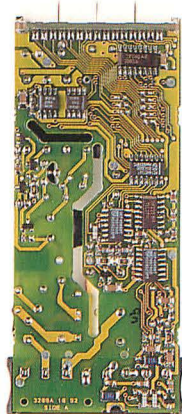

Input mV range: -10 to 50mV

See "PIM Process Interface Module" for additional input/output options

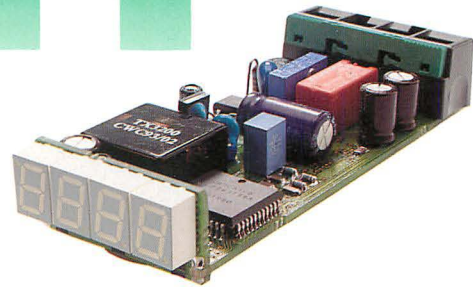

Applicable to all inputs

SM = sensor maximum

Calibration accuracy:

$\pm 0.25\% \text{SM} \pm 1^\circ\text{C}$

Linearity:

5–95% sensor range

Sampling frequency:

Input 10Hz, CJC 2 sec

Common mode rejection:

Negligible effect up to 140dB, 240V, 50–60Hz

Series mode rejection:

60dB, 50–60Hz

Temperature coefficient:

150 ppm/°C SM

Reference conditions:

22°C $\pm 2^\circ$, rated voltage, after 15 mins settling time

Output devices (two)



Miniature power relay:

2A/250V~ resistive load
 Form A/SPST (AgCdO)



Solid state relay drive:

To switch a remote SSR
 5Vdc +0/-15% 10mA
 non-isolated

Today, small is not only beautiful – it's powerful too!

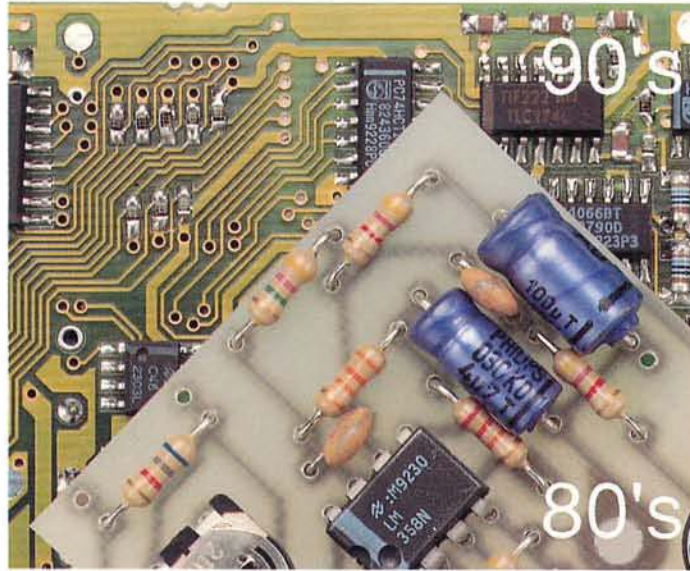

30
years
temperature
control
innovation

George R. Peters *Associates* **ENGINEERING**
SALES REPRESENTATIVES

650 E. Big Beaver • Suite C • Troy, MI 48083
(248) 524-2211 • Fax (248) 524-1758
www.grpeters.com



CAL Controls
Temperature Controllers

CAL Controls Ltd

Bury Mead Road, Hitchin, Herts, SG5 1RT, UK
Tel: +44 (0) 1462-436161 Fax: +44 (0) 1462-451801

CAL Controls Inc

1580 S. Milwaukee Avenue, Libertyville, IL 60048
Tel: (847) 680-7080 Fax: (847) 816-6852

131 0596