

S:\AFMMachines\15000 Foil Feed Systems\15750 Rail\_Mounts\15750\_Rail\_Mounts\_KF1000\

ITEM NO.	PART NUMBER	PartNo	DESCRIPTION	QTY.
1	001_15750_Rail_Mounts_KF1000	105069	MOUNT ADAPTER	2
2	001_KF1000_connection_box_Mount	105073	KF1000 connection box mount	1
3	000_37500 Connection_Box	104634	Electrical Connection Box	1
4	KF1000_Ram	-	-	1

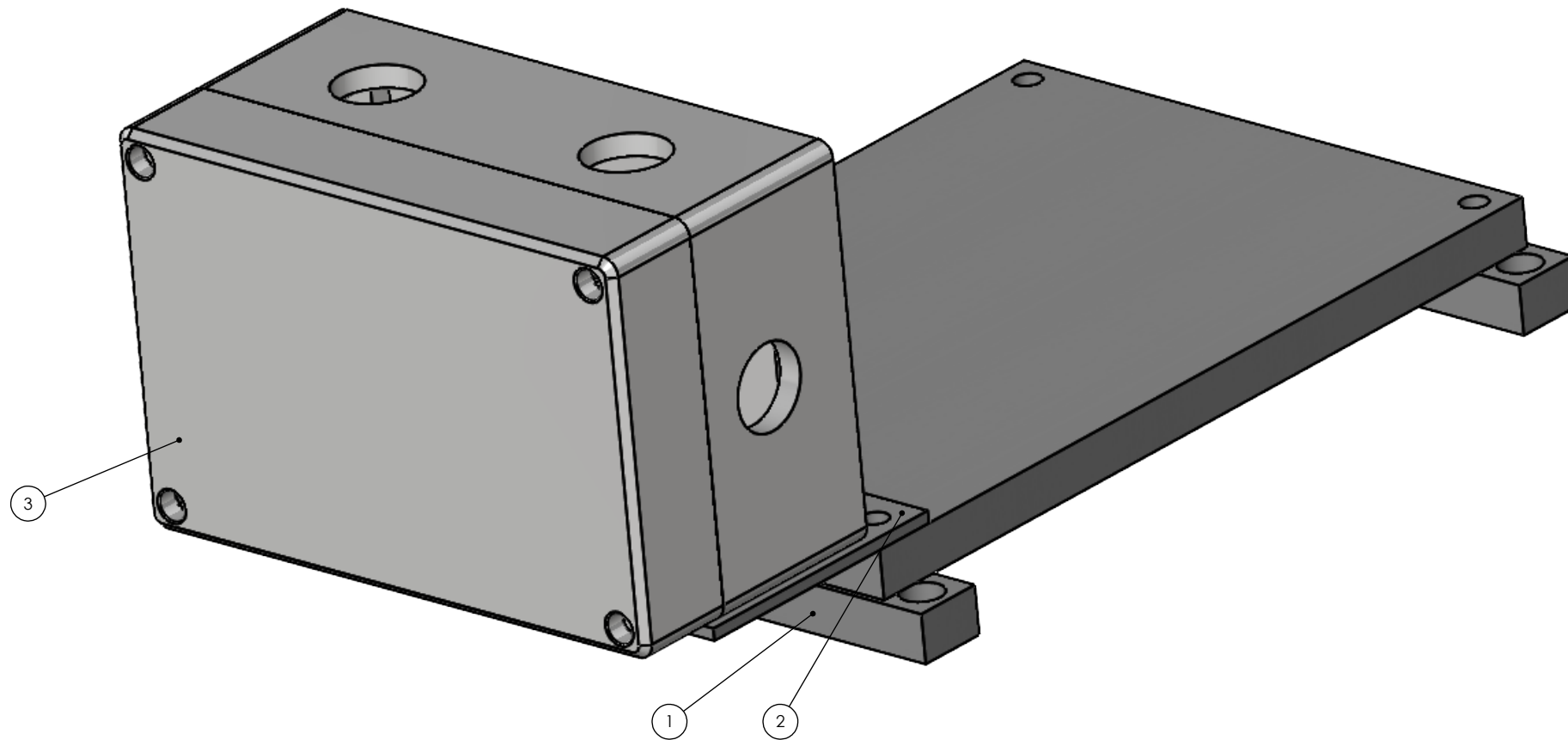

**PROPRIETARY AND CONFIDENTIAL**  
 THE INFORMATION CONTAINED IN THIS DRAWING IS THE SOLE PROPERTY OF AFM ENGINEERING, INC. ANY REPRODUCTION IN PART OR AS A WHOLE WITHOUT THE WRITTEN PERMISSION OF AFM ENGINEERING INC. IS PROHIBITED.

		DIMENSIONS ARE IN INCHES		NAME		DATE	
		TOLERANCES:		DRAWN		-	
		FRACTIONAL ±		CHECKED		-	
		ANGULAR: MACH ± BEND ±		ENG APPR.			
		TWO PLACE DECIMAL ± .010		MFG APPR.			
		THREE PLACE DECIMAL ± .005		Q.A.			
		MATERIAL		COMMENTS:			
NEXT ASSY	USED ON	FINISH					
APPLICATION		DO NOT SCALE DRAWING					
<b>AFM Engineering, Inc.</b>							
<b>AFM Engineering Foil Feed Mount Adapters Rail Mounts_KF1000 AFM PART # 105074</b>							
SIZE	DWG. NO.				REV.		
<b>B</b>	000_15750_Rail_Mounts_KF1000						
SCALE: 1:4				WEIGHT: 4.055		SHEET 1 OF 2	

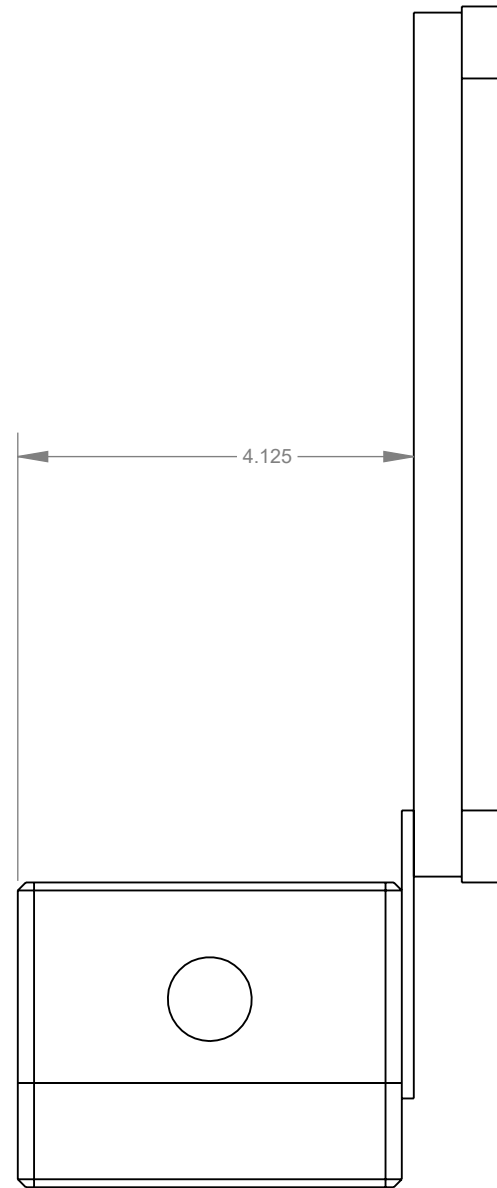
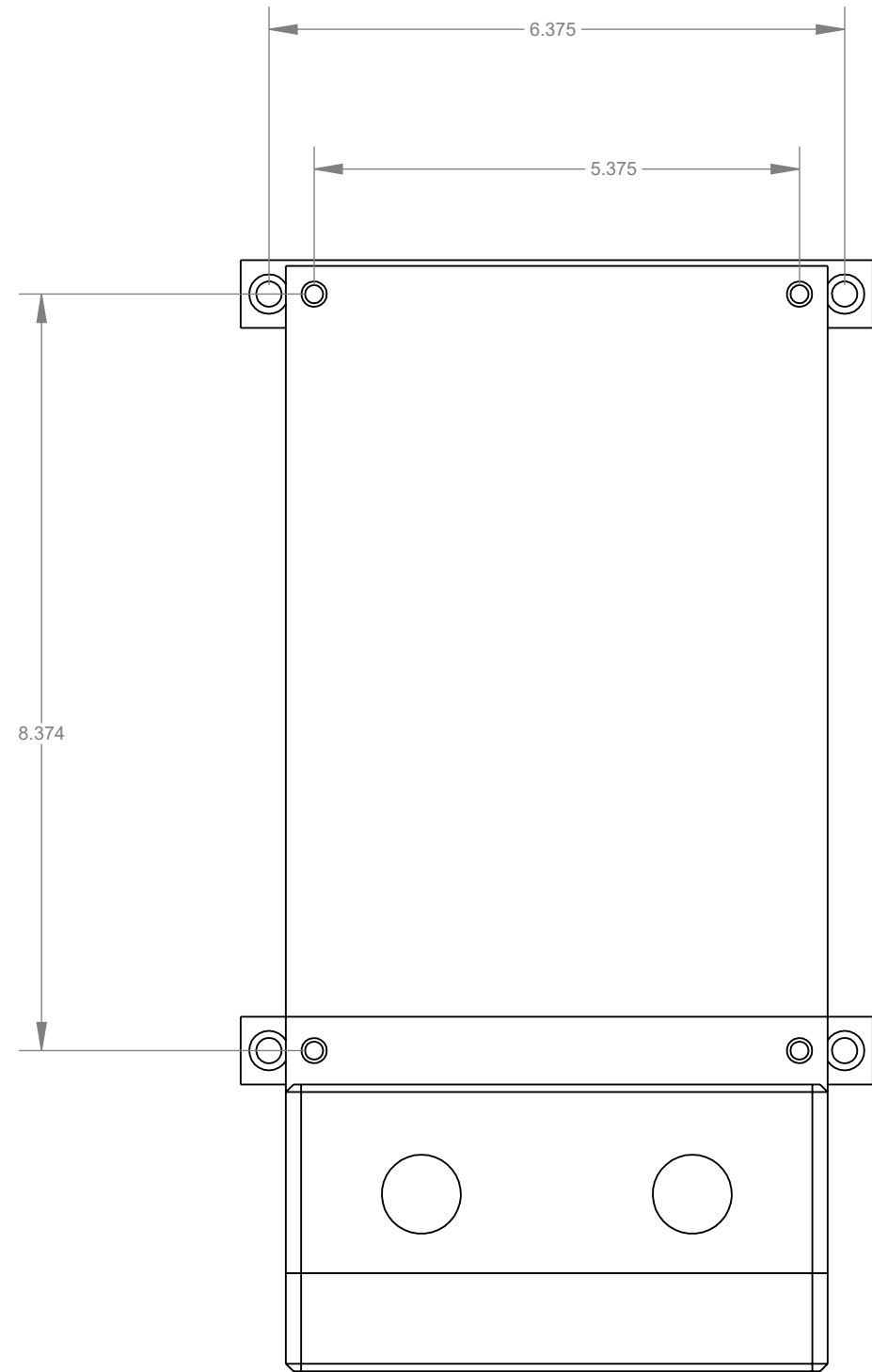

**PROPRIETARY AND CONFIDENTIAL**  
 THE INFORMATION CONTAINED IN THIS DRAWING IS THE SOLE PROPERTY OF AFM ENGINEERING, INC. ANY REPRODUCTION IN PART OR AS A WHOLE WITHOUT THE WRITTEN PERMISSION OF AFM ENGINEERING INC. IS PROHIBITED.

		DIMENSIONS ARE IN INCHES		NAME		DATE	
		TOLERANCES:		DRAWN		-	
		FRACTIONAL ±		CHECKED		-	
		ANGULAR: MACH ± BEND ±		ENG APPR.			
		TWO PLACE DECIMAL ± .010		MFG APPR.			
		THREE PLACE DECIMAL ± .005		Q.A.			
		MATERIAL		COMMENTS:			
NEXT ASSY	USED ON	FINISH					
APPLICATION		DO NOT SCALE DRAWING					
<b>AFM Engineering, Inc.</b>							
<b>AFM Engineering Foil Feed Mount Adapters Rail Mounts_KF1000 AFM PART # 105074</b>							
SIZE	DWG. NO.						REV.
<b>B</b>	<b>000_15750_Rail_Mounts_KF1000</b>						
SCALE: 1:4 WEIGHT: 4.055							SHEET 2 OF 2