

REV	DATE	CHANGE	TR NO.	REV BY.

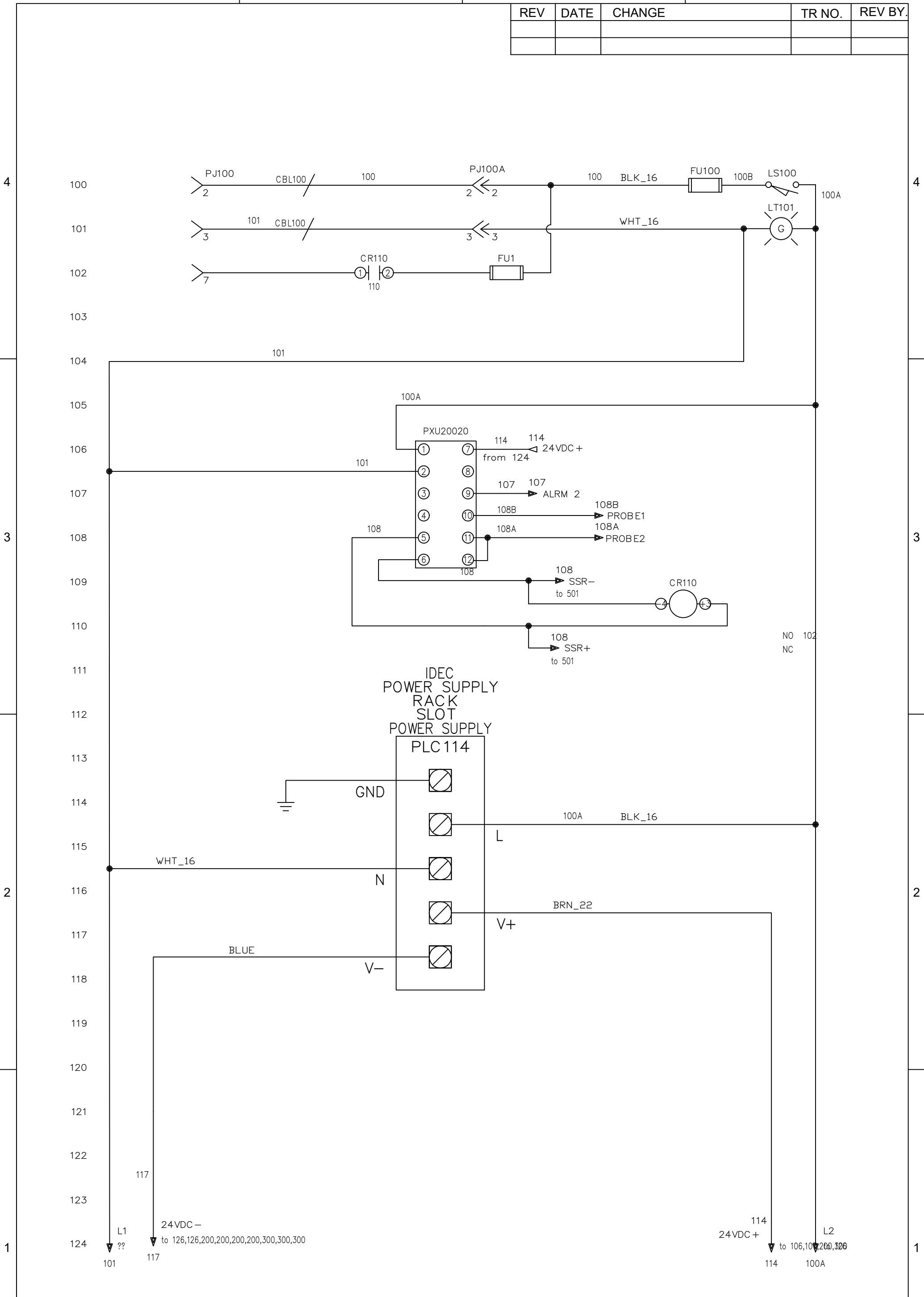

S:\AFMMachines\19000 Hot Stamp Control Box\19070\_IDEC\19070\_ Idec\_FT1A-C12RA-S\100-1.dwg



TITLE AFM ENGINEERING, INC.  
POWER INPUT  
19070\_Idec\_FT1A-C12RA-S

DRAWING NO. 100-1 SHEET 1 OF 5

DESIGNED BY C.S.I. 9/24/2023  
DRAWN BY C.S.I. 9/24/2023  
CHECKED BY C.S.I. 9/24/2023  
APPROVED BY C.S.I. 9/24/2023

REV	DATE	CHANGE	TR NO.	REV BY.

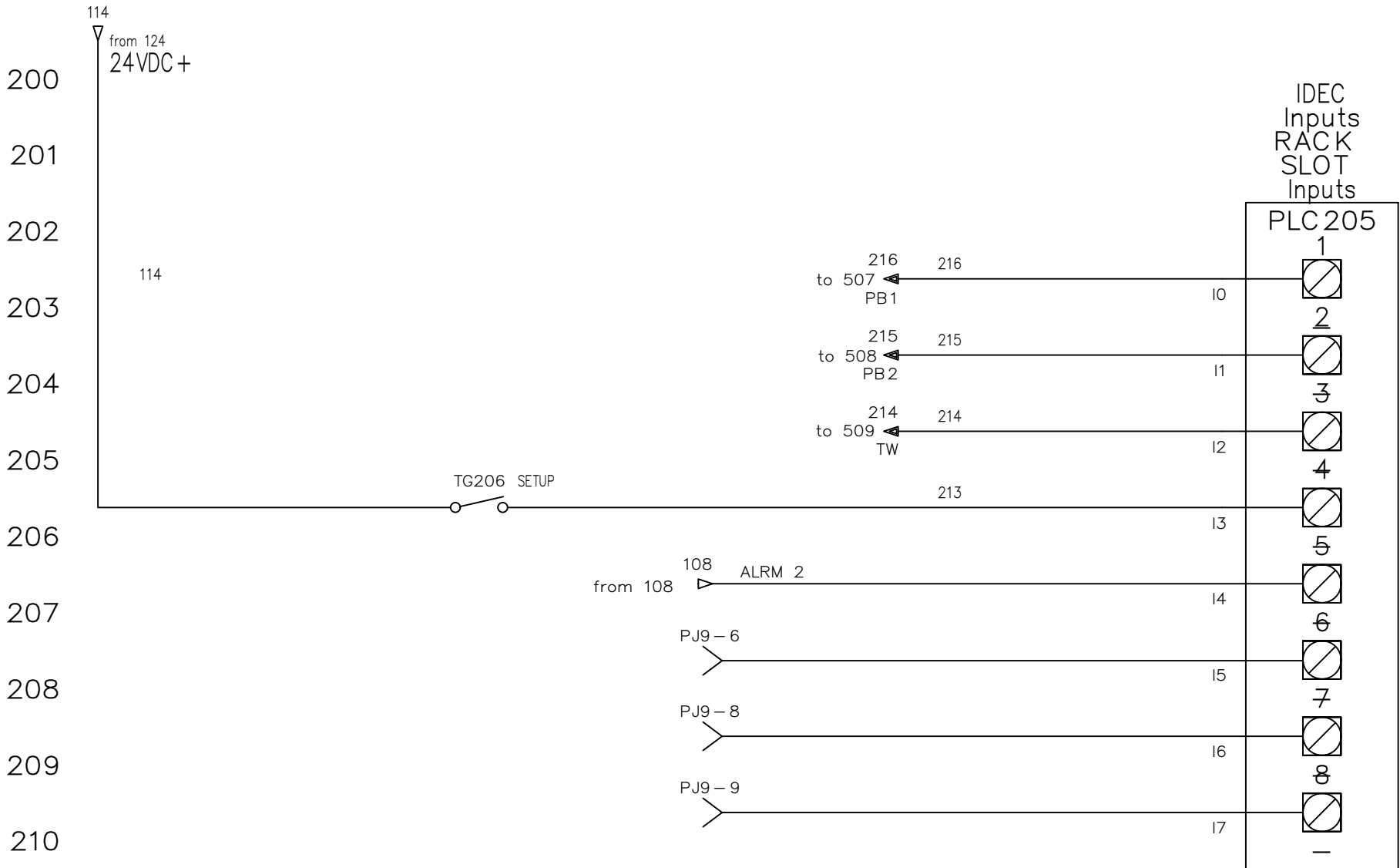

S:\AFMMachines\19000 Hot Stamp Control Box\19070\_IDEC\19070\_ Idec\_FT1A-C12RA-S\200-1.dwg



TITLE AFM ENGINEERING, INC.  
INPUTS  
19070\_ Idec\_FT1A-C12RA-S

DRAWING NO. 200-1 SHEET 2 OF 5

DESIGNED BY C.S.I. 9/24/2023  
DRAWN BY C.S.I. 9/24/2023  
CHECKED BY C.S.I. 9/24/2023  
APPROVED BY C.S.I. 9/24/2023

REV	DATE	CHANGE	TR NO.	REV BY.

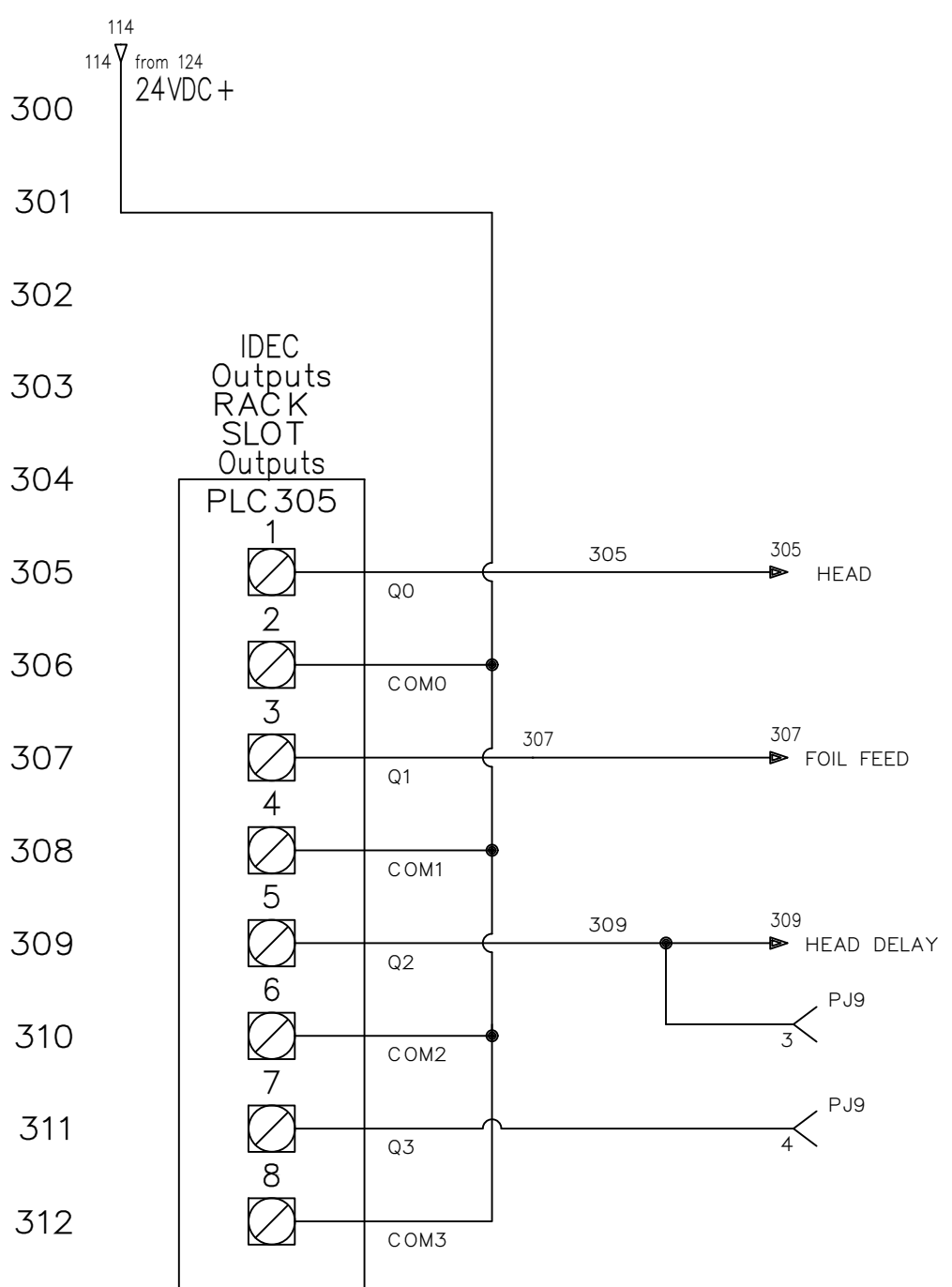

S:\AFMMachines\19000 Hot Stamp Control Box\19070\_IDEC\19070\_ Idec\_FT1A-C12RA-S\300-1.dwg



TITLE AFM ENGINEERING, INC.  
OUTPUTS  
19070\_Idec\_FT1A-C12RA-S

DRAWING NO. 300-1 SHEET 3 OF 5

DESIGNED BY C.S.I.	9/24/2023
DRAWN BY C.S.I.	9/24/2023
CHECKED BY C.S.I.	9/24/2023
APPROVED BY C.S.I.	9/24/2023

REV	DATE	CHANGE	TR NO.	REV BY.

# CONTROL BOX BOARD AND CABLES REV 7

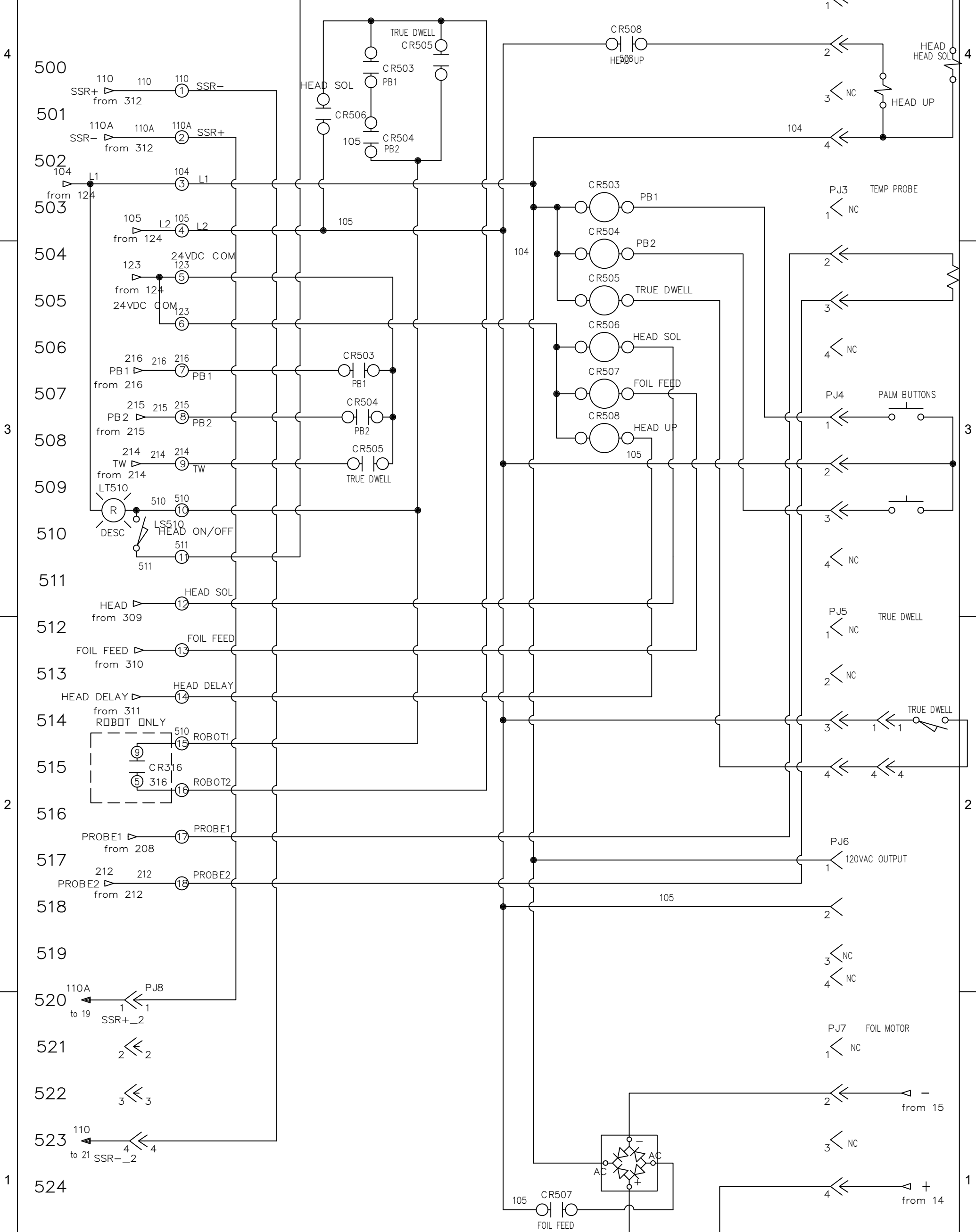

S:\AFMMachines\19000 Hot Stamp Control Box\19070\_IDEC\19070\_ Idec\_FT1A-C12RA-S\500-1.dwg



TITLE AFM ENGINEERING, INC.  
PC BOARD  
19070\_Idec\_FT1A-C12RA-S  
DRAWING NO. 500-1 SHEET 4 OF 5

DESIGNED BY C.S.I. 9/24/2023  
DRAWN BY C.S.I. 9/24/2023  
CHECKED BY C.S.I. 9/24/2023  
APPROVED BY C.S.I. 9/24/2023

REV	DATE	CHANGE	TR NO.	REV BY.

THIS SHEET USED ONLY IF 9  
PIN INTERFACE PLUG IS USED

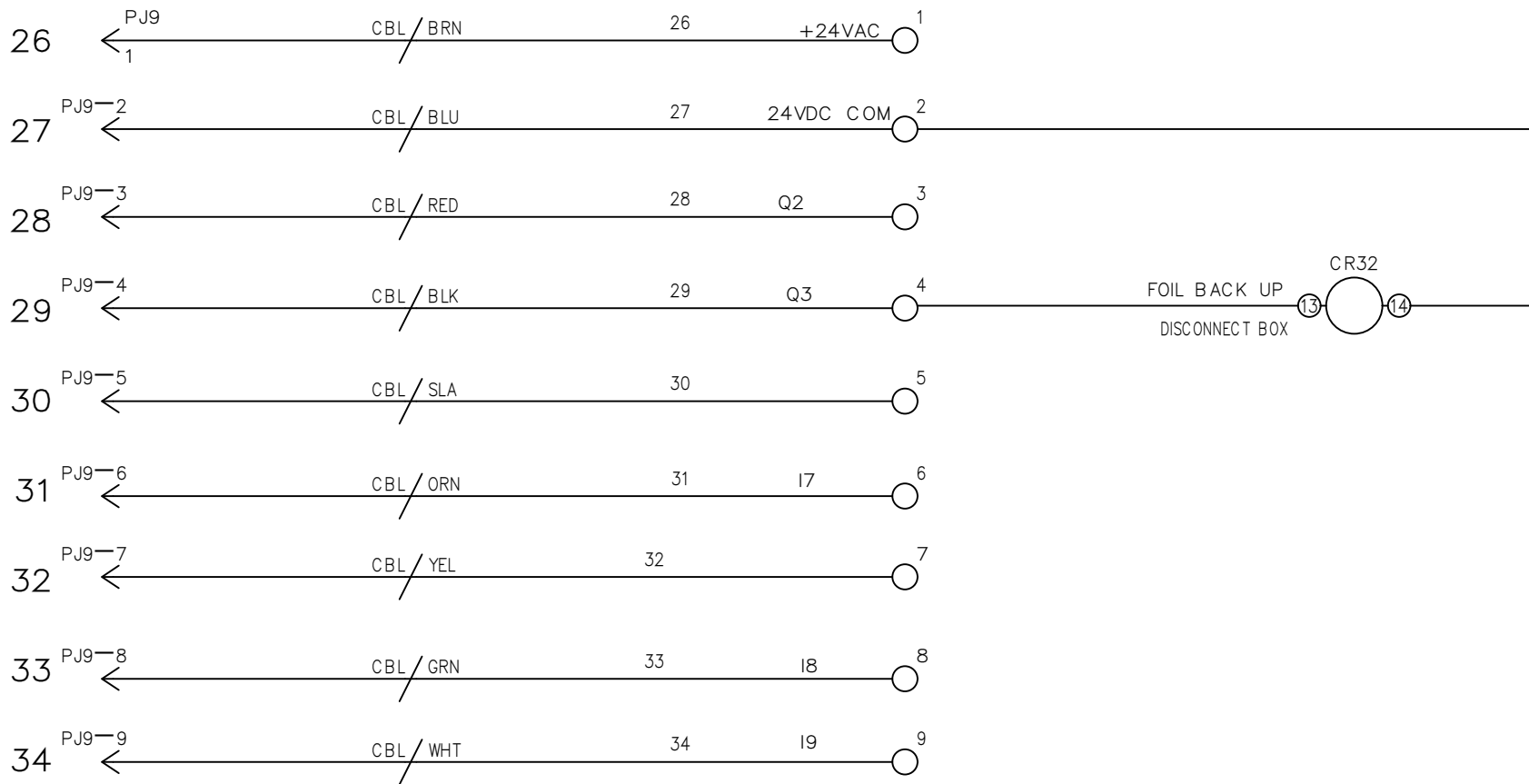

40,42  
41,43

35  
36  
37  
38  
39  
40  
41  
42  
43  
44  
45  
46  
47  
48  
49  
50

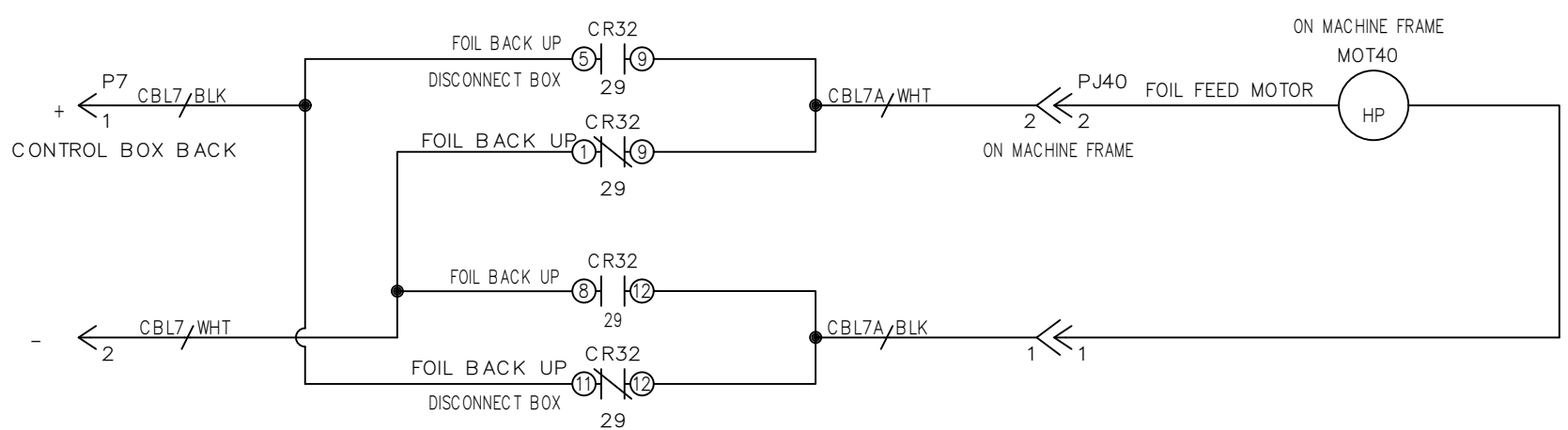

S:\AFMMachines\19000 Hot Stamp Control Box\19070\_IDEC\19070\_Idec\_FT1A-C12RA-S\600-1.dwg



TITLE AFM ENGINEERING, INC.  
9 PIN CABLE  
19070\_Idec\_FT1A-C12RA-S  
DRAWING NO. 600-1 SHEET 5 OF 5

DESIGNED BY C.S.I. 9/24/2023  
DRAWN BY C.S.I. 9/24/2023  
CHECKED BY C.S.I. 9/24/2023  
APPROVED BY C.S.I. 9/24/2023

A B C D